

USE & CARE MANUAL



REVOLUTION 2

chocolate tempering system

ChocoVision
Technology MEANS PRODUCTIVITY

314 MILL STREET, POUGHKEEPSIE, NY 12602
TEL (845) 473-4970 (845) 473-5453 FAX (845) 473-8004



www.chocovision.com

INTRODUCTION

Congratulations on your purchase of the new Revolution 2 Chocolate Tempering Machine by ChocoVision

The ChocoVision line of "Revolution Chocolate Makers" has been widely accepted among the homemakers, hobbyists, restaurants, hotels, coffee shops, bakeries, and even highly accomplished pastry chefs. For the first time ever, the complicated process of properly tempering chocolate can be easily performed by anyone.

By combining the subtle nuance of precise temperature control with sophisticated computer controlled electronics, the "Revolution" line of Chocolate Tempering Machines has proven itself a serious performer in this demanding environment.

We hope you will enjoy the use of your Revolution 2 Chocolate Tempering Machine for many years to come. It has been designed to provide the user with precision, accuracy, efficiency, and unmatched reliability. We take great pride in providing you with the highest quality product and superior service.

TABLE OF CONTENTS

| | |
|------------------------------|---|
| INTRODUCTION / CONTENTS..... | 1 |
| SAFETY TIPS..... | 2 |
| YOUR MACHINE..... | 3 |
| ASSEMBLY..... | 4 |
| THE CONTROLS..... | 5 |
| USING YOUR MACHINE..... | 5 |
| TIPS..... | 6 |
| BEFORE YOU CALL SERVICE..... | 6 |
| CLEANING..... | 7 |
| QUICK START..... | 7 |

IMPORTANT SAFETY TIPS

PLEASE READ AND UNDERSTAND THE FOLLOWING SAFETY MEASURES BEFORE USING YOUR MACHINE

-FOR PERSONAL SAFETY, THIS APPLIANCE MUST ALWAYS BE PLUGGED INTO A PROPERLY GROUNDED ELECTRICAL CIRCUIT.

-DO NOT CUT OR REMOVE THE THIRD (GROUND) PRONG FROM THE POWER PLUG, OR ATTEMPT TO USE A GROUNDING ADAPTOR.

-NEVER IMMERSE THE MACHINE IN WATER. (SEE CLEANING INSTRUCTIONS ON PAGE 7.)

-ALWAYS LOCATE THE MACHINE AWAY FROM ANY WATER SOURCE. AVOID WATER SPLASHING ON TOP OR INTO THE MACHINE, OR NEAR THE FAN AREAS.

-NEVER USE EXTENSION CORDS TO POWER THE MACHINE.

-TO AVOID SUFFOCATION, KEEP ALL PACKING MATERIAL, (PLASTIC BAGS AND SMALL PARTS) AWAY FROM CHILDREN.

-POSITION MACHINE SUCH THAT THE INTAKE AND EXHAUST FANS ARE NOT OBSTRUCTED, OR THAT ANY LOOSE OBJECTS CAN NOT BLOCK AIR FLOW.

-UNPLUG MACHINE FROM POWER SOURCE WHEN NOT IN USE.

-ALWAYS UNPLUG YOUR MACHINE BEFORE CLEANING. NEVER USE SPRAY SOLVENTS OR CLEANING FLUIDS NEAR THE MACHINE.

-TO AVOID ELECTRICAL SHOCK, NEVER OPEN CASE.

-NEVER ALLOW MELTED CHOCOLATE TO HARDEN IN THE BOWL WITH THE BAFFLE IN PLACE. ACCIDENTAL STARTING OF THE MACHINE IN THIS CONDITION COULD CAUSE INTERNAL COMPONENT DAMAGE, OR PRESENT ELECTRICAL HAZARDS.

YOUR MACHINE

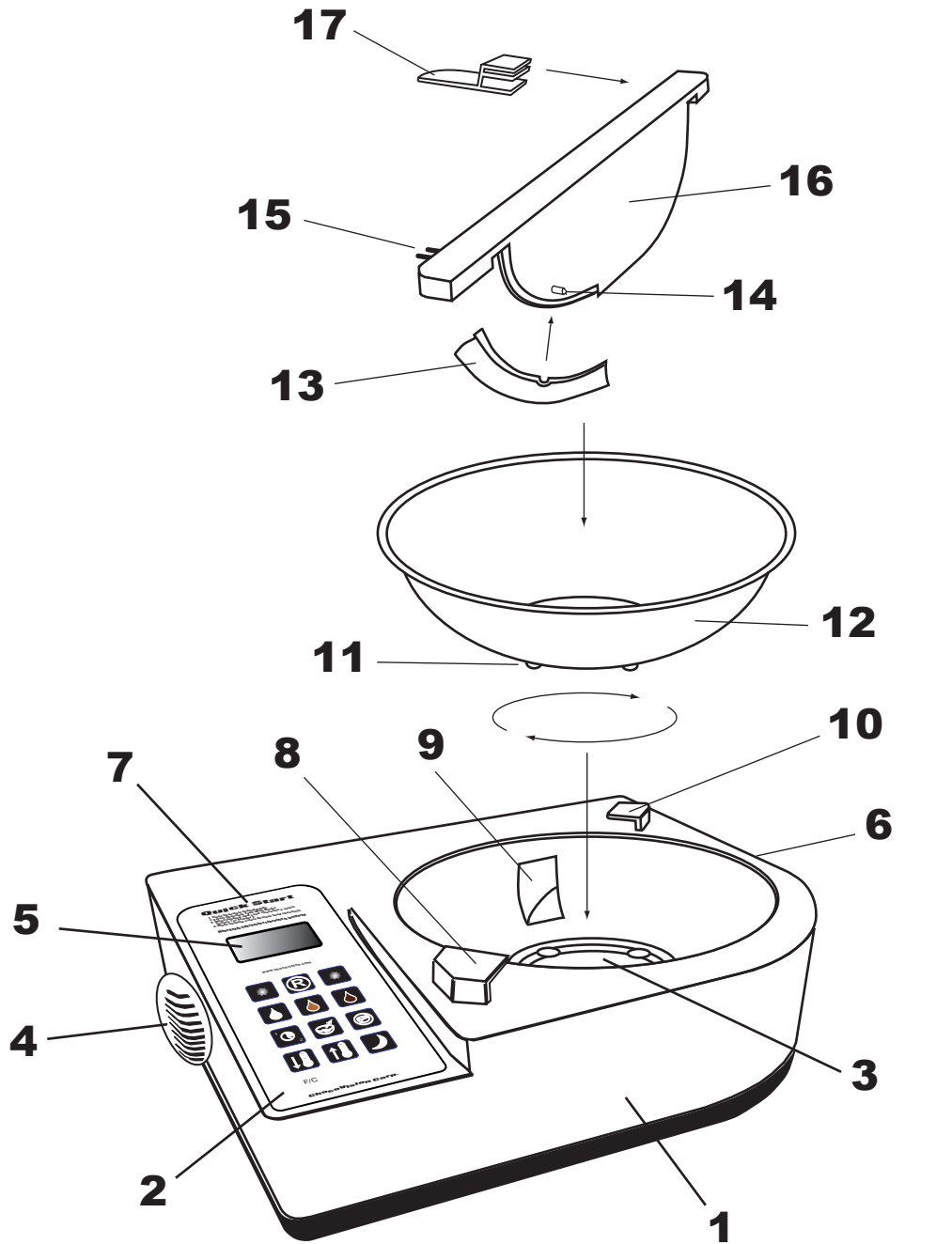

1. CASE
2. KEYPAD
3. BOWL LOCK
4. EXHAUST AIR
5. LED DISPLAY
7. QUICK START INSTRUCTIONS
8. BAFFLE LOCK (CONNECTOR)
9. HEAT DUCT

10. BAFFLE LOCK
11. BOWL LOCK PINS
12. BOWL
13. SCRAPER
14. PROBE
15. BAFFLE CONNECTOR PINS
16. BAFFLE
17. BAFFLE CLIP

NOTE: BEFORE USING YOUR MACHINE, WASH ALL COMPONENTS THAT MAY COME IN CONTACT WITH CHOCOLATE, USING A SOFT SPONGE OR CLOTH, AND MILD SOAP.

* Place the BOWL in your machine and rotate the BOWL until it drops into place.

* Attach the SCRAPER to the BAFFLE (Fig. 1). When properly installed, the SCRAPER should curve towards the front of the machine (Fig. 1).

NOTE: To avoid damage to your scraper it is recommended that your BOWL/SCRAPER be "primed" for the first few uses. To do so, take a small piece of unmelted chocolate, and simply rub it on the inside of the bowl. This will insure a smooth initial start up.

* Fit the BAFFLE into the BOWL by rotating the BAFFLE clockwise until the BAFFLE CONNECTOR PINS engage into BAFFLE LOCK (CONNECTOR) (Fig. 2).

* Slide the BAFFLE CLIP on to the BAFFLE (Fig. 1). This helps the solid chocolate from climbing out of the bowl as it rotates.

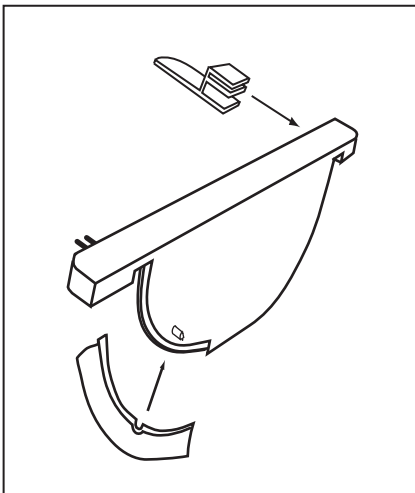

Fig. 1

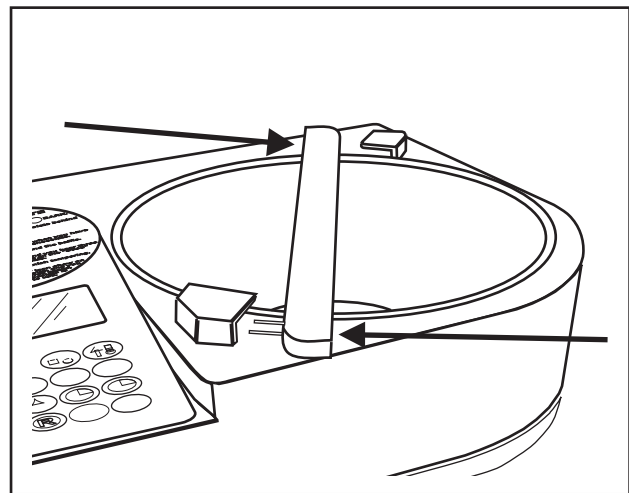
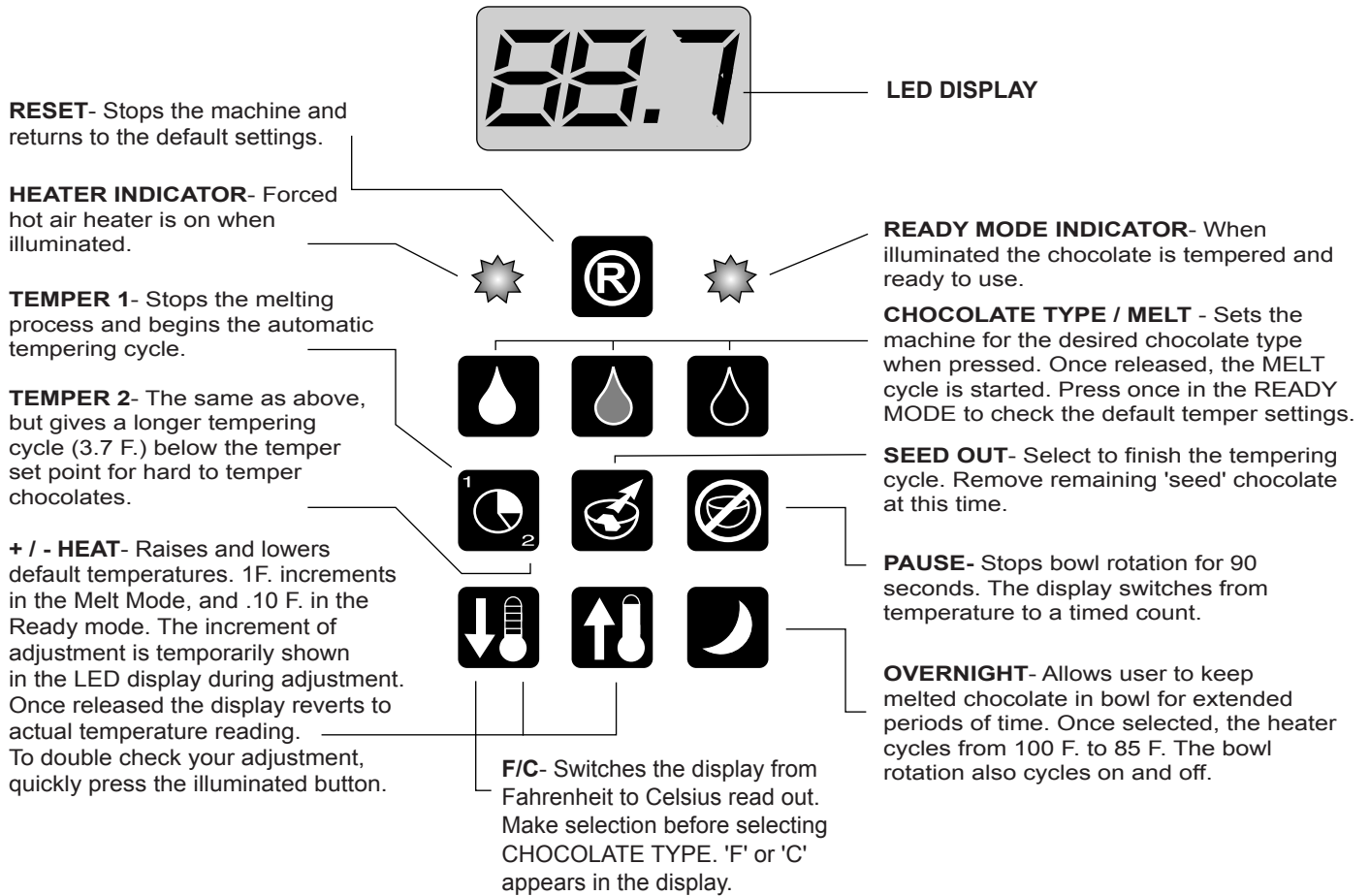

Fig. 2

THE CONTROLS



USING YOUR MACHINE

1) Assemble and plug in your machine. Load chocolate behind the baffle. (Solid block pieces work best). You can load up to 1.5 lbs. of chocolate at a time.

2) Select the type of chocolate you wish to temper by pressing for WHITE, for MILK, or for DARK. Once released the Melting process begins. As the chocolate begins to melt it will collect in a pool in front of the SCRAPER, near the PROBE. Depending on the average room conditions, it will take approximately 10-12 minutes to melt 1.5 lbs of chocolate. *Melted chocolate should never rise above the top of the SCRAPER.*

NOTE: If the chocolate your using requires a higher than 108F. melt temperature, press and hold the +HEAT. To check the default Melt temperature, press CHOCOLATE TYPE/MELT during the melting process.

3) Once flashing, and you have the desired amount of chocolate melted, press the TEMPER 1 button. If 'Seed' chocolate is not in good condition, press and hold the button for TEMPER 2.

5) Place at least 112 gms (4 oz) of solid, tempered chocolate (See 'Seed' chocolate on page 6 under TIPS & HELPFUL HINTS) behind the baffle, per batch. The tempering process will take around 6-10 minutes.

6) Press the SEED OUT button when flashing, and remove any remaining 'Seed' chocolate at this time. This will happen at a nominal 90F.



When the machine finishes the final phase of tempering, you will hear three beeps, the READY INDICATOR light illuminates. The chocolate is now tempered and is ready to use.

TIPS & HELPFUL HINTS

TEMPERING LARGE QUANTITIES. You can replenish the pool of chocolate by adding pre-melted batches behind the baffle while in the TEMPER mode. We recommend that the pre-melted chocolate temperature does not exceed 34 C. (94 F). Set the machine to the MELT mode if you do not plan on using your tempered chocolate for extended periods of time (over two hours). Re-temper when chocolate is needed again.

WORK AREA. The ideal average room temperature should be between 20-22 C. (68-72 F.), with the average humidity not above 50 %. Air conditioned environments work best. Never allow water to mix with melted chocolate. Never store chocolate in a refrigerated environment, as condensation (water) may form on the chocolate surface when brought out at room temperature. Always make sure that all items being dipped into the tempered chocolate (like fruit), are at room temperature, and COMPLETELY dry, including all utensils being used.

PRODUCT SIZE. If you are producing solid thick products, like molds, thoroughly mix the tempered chocolate batch before you pour. With a fan, moving large volumes of air across the product helps in the cooling process.

TEMPERATURE / THICKNESS. You can manually adjust the viscosity of your tempered chocolate by adjusting the temperature setting in the READY mode. Increasing the heat will make the chocolate thinner, and decreasing the heat will make the chocolate thicker. To do so, press and hold the buttons marked  + HEAT or  - HEAT. Each stroke of these buttons raises and lowers the temperature in .01 F. steps. Button illumination is accompanied with heat adjustment for quick view convenience. To check the custom temperature adjustment, press the illuminated HEAT button once and your adjustment will appear in the LED display. Once released the display reverts to the actual temperature reading.

'SEED' CHOCOLATE. This is solid tempered chocolate that has the proper crystalline structure. To dramatically improve on tempering time, 'seed' chocolate is slowly added to untempered chocolate, therefore aiding in the proper crystal structure of the liquid pool.

BEFORE YOU CALL FOR SERVICE.....

? MY MACHINE WON'T START. Make sure that the **BAFFLE CONNECTOR PINS** are fully engaged into the **BAFFLE LOCK (CONNECTOR)**, and are making a good connection. These contacts should be clean and free of chocolate at all times.

? MY SCRAPER IS DAMAGED. Make sure that you "prime" your bowl as described on page 4 - **ASSEMBLY** - attaching the scraper.

? THE MELTED CHOCOLATE DOES NOT POOL IN FRONT OF THE BAFFLE. Check the installation of the **SCRAPER**. The **SCRAPER** should be curved forward (against the **BOWL**, and towards the front of the machine) when properly installed into the **BAFFLE** (page 4).

? THE CHOCOLATE THICKENS. The chocolate may have picked up moisture from dipping fresh fruits, or from high room humidity (see above under **TIPS & HELPFUL HINTS**). The pool of chocolate was left in the **TEMPER** mode too long. (see above under **TIPS & HELPFUL HINTS**). The 'seed' chocolate was not removed on time, causing the tempered pool to thicken. You can simply press the **MELT** button and start over.

? THE CHOCOLATE CLIMBS OUT OF THE BOWL. Make sure that the **BAFFLE CLIP** is properly installed onto the **BAFFLE**. Solid block chocolate works best.

? WHERE DO I SEND MY MACHINE IF IT IS IN NEED OF REPAIR. Your machine should be sent back to the original point of purchase. Please call and get proper authorization before shipping your machine back.

CLEANING

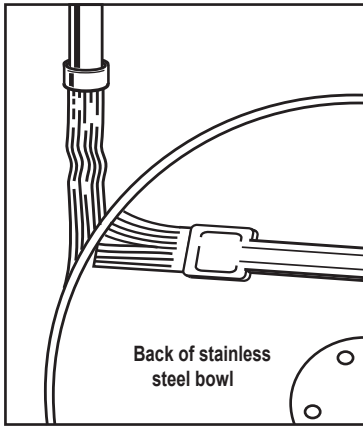

FIG. 1

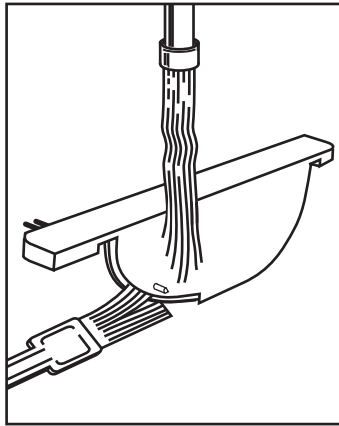

FIG. 2

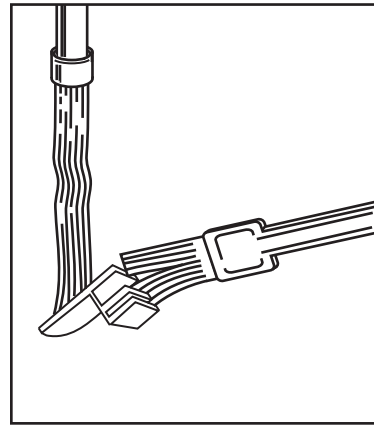
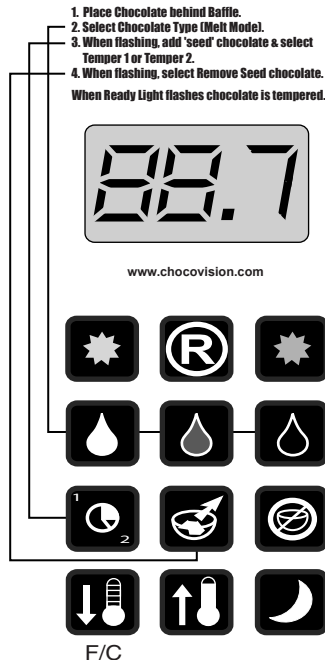

FIG. 3

Your machine includes a special **CLEANING BRUSH** for areas where chocolate collects and may be difficult to clean, such as behind the lip of the stainless steel **BOWL** (Fig. 1), and crevices on the **BAFFLE** (Fig.2) and the **BAFFLE CLIP** (Fig. 3)

Never use steel wool or any other type of abrasive to clean your machine, or any components included with your machine. Only use a sponge or a soft cloth with mild soap to wipe down the outside **CASE**. All loose components are dishwasher safe.

QUICK START



MANUFACTURED IN THE U.S.A. WITH PRIDE AND CRAFTSMANSHIP

ChocoVision Corporation

14 Catharine Street, Poughkeepsie, NY 12601 (845) 473-4970 FAX (845) 473-8004 www.chocovision.com